

Squedge in the Window

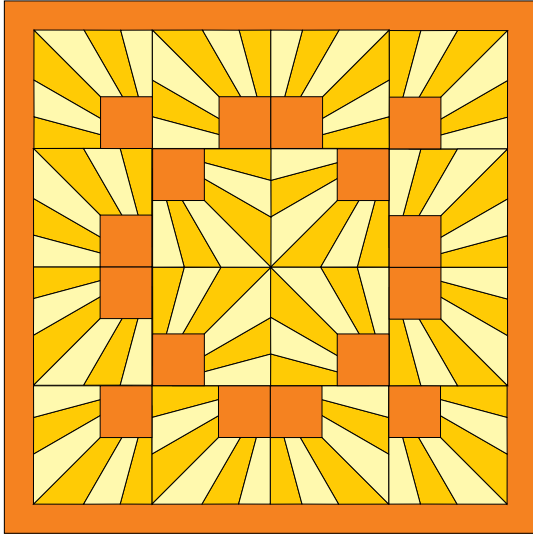

I really liked the way the Attic Window folded into the seam to cover the opening while giving the project dimension.

*With no need to applique, it was **magic!***

The Squedge 15 combined with the Attic Window tool to produce an amazing lap or baby quilt.

Fabric	Number of strips / pieces per strip	Strip width	Suggested Yardage
A	two / 8	8" x fabric width	1 ¼ yd
	one / 17	7 ¾" x fabric width	
	one / 20	7 ½" x fabric width	
B	two / 8	8" x fabric width	1 ¼ yd
	one / 17	7 ¾" x fabric width	
	one / 20	7 ½" x fabric width	
C	two / 8	8 ¼" x fabric width	¾ yd
Border & Binding		(four) 2.5" x 38" each	⅝ yd each
Backing		38" x 38"	3
Batting		38" x 38"	⅝ yd

Finished Size: 32" x 32"

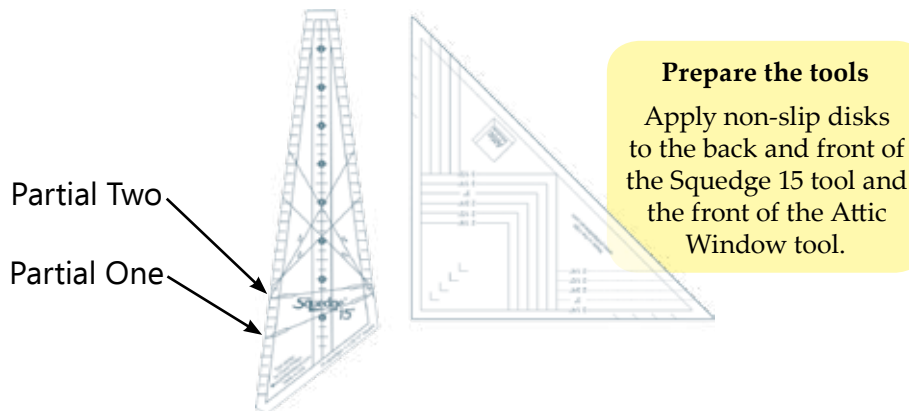

Cutting Full Squedges

Place the Squedge 15 tool on the bottom edge of the strip for Full Squedge pieces. Rotate the tool to get the most out of each strip.

- Cut **eight** Squedge 15 Full pieces from Fabric A.

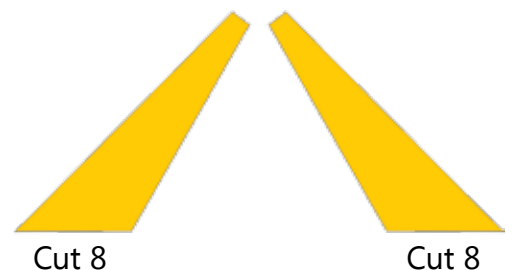

Cutting Full Squedges

Place the Squedge 15 tool on the bottom edge of the strip for Full Squedge pieces. Rotate the tool to get the most out of each strip.

- Flip the tool over, after cutting the Full Fabric A pieces.
- Cut *eight* Squedge 15 Reverse Full pieces from Fabric B.

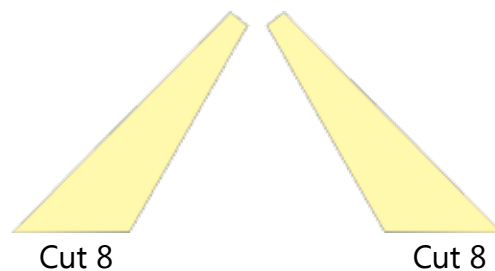
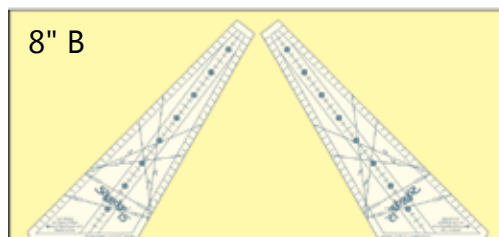

Cutting Partial One Squedges

Place the Squedge 15 tool aligning the partial one on the bottom edge of the strip for Full Squedge pieces. Rotate the tool to get the most out of each strip.

- Cut *eight* Squedge 15 Partial One pieces from Fabric A.
- Flip the tool over.
- Cut *eight* Squedge 15 Reverse Partial One pieces from Fabric A.
- Cut *eight* Squedge 15 Partial One pieces from Fabric B.
- Flip the tool over.
- Cut *eight* Squedge 15 Reverse Partial One pieces from Fabric B.

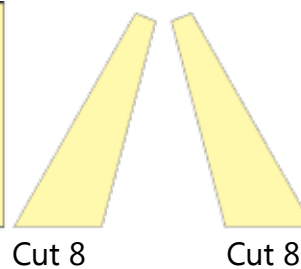
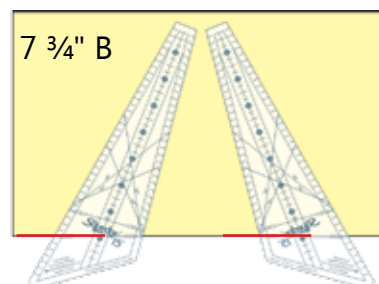
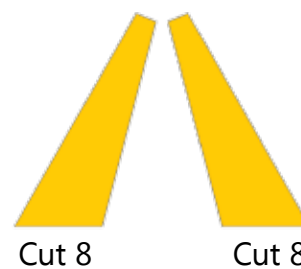
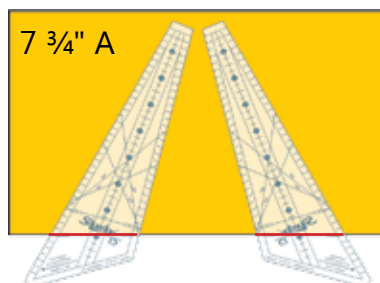

Cutting Partial Two Squedges

Place the Squedge 15 tool aligning the partial two on the bottom edge of the strip for Full Squedge pieces. Rotate the tool to get the most out of each strip.

- Cut *eight* Squedge 15 Partial Two pieces from Fabric A.
- Flip the tool over.
- Cut *eight* Squedge 15 Reverse Partial Two pieces from Fabric A.
- Cut *eight* Squedge 15 Partial Two pieces from Fabric B.
- Flip the tool over.
- Cut *eight* Squedge 15 Reverse Partial Two pieces from Fabric B.

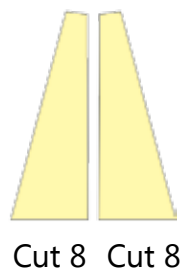
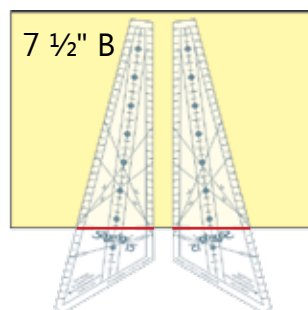
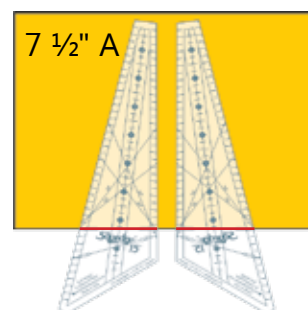

Cutting Attic Window Pieces

- Align the Attic Window tool to the bottom edge of the strip.
- Cut around the entire tool.
- Rotate the tool to get the most out of each strip.
- Cut **sixteen** Attic Window Pieces.

For more information on cutting Attic Window pieces including all the other sizes and fussy cutting, refer to the Attic Window instruction booklet.

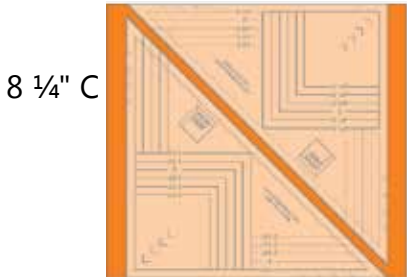

- Fold each Attic Window triangle in half with wrong sides facing each other.

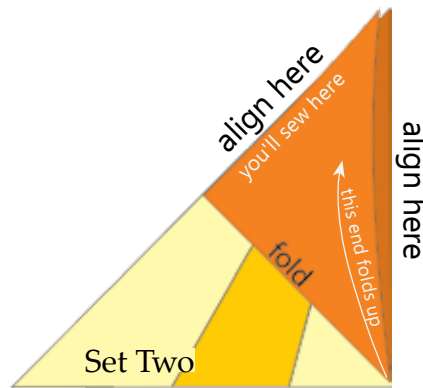
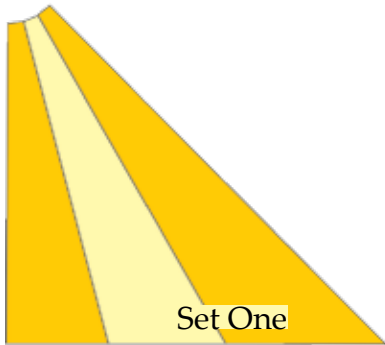

Assembling Sets

- Sew sets of three Squedge pieces together to make each set as shown.

- Set One (make 8)
- Set Two (make 8)
- Set Three (make 8)
- Set Four (make 8)

- Group sets together:
 - Sets One and Two
 - Sets Three and Four

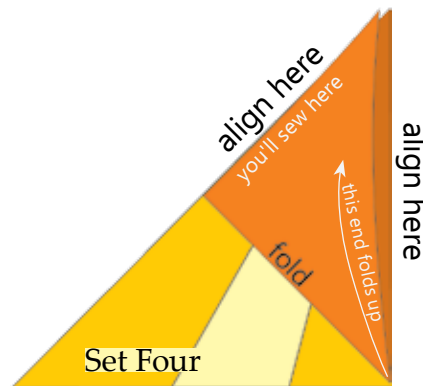
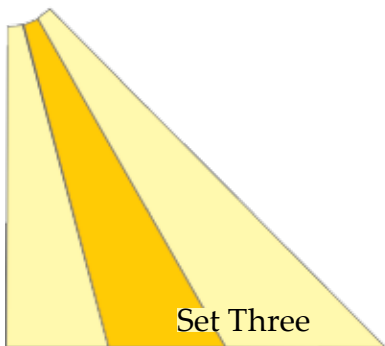

Adding Corners

- Align Attic Window triangle to the both diagonal edge and the right edge of Set Two.

Keep the fold towards the bottom.

- Repeat for Set Four.

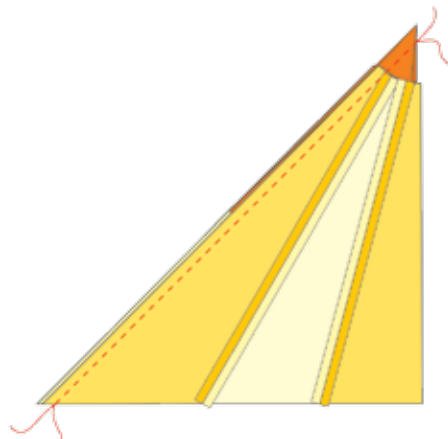
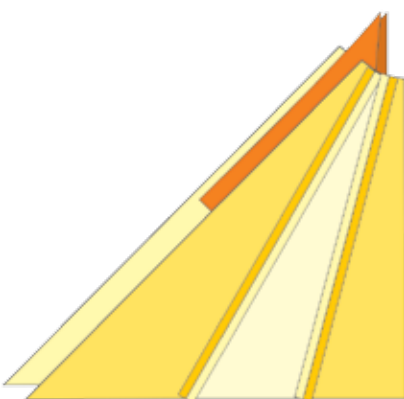

- Place Set One on top of Set Two.
- Place Set Three on top of Set Four.
- Sew each pair with 1/4" seam allowances.

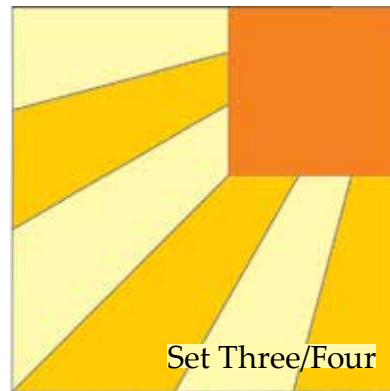
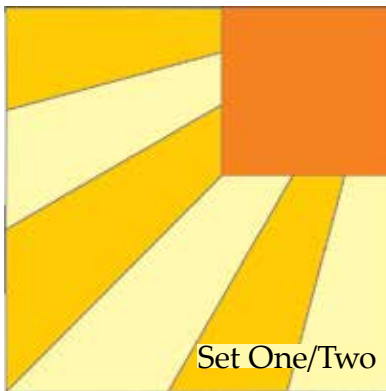

- Open and finger press each side of your Attic Window.
- Sew *eight* Set One/Two and *eight* Set Three/Four.

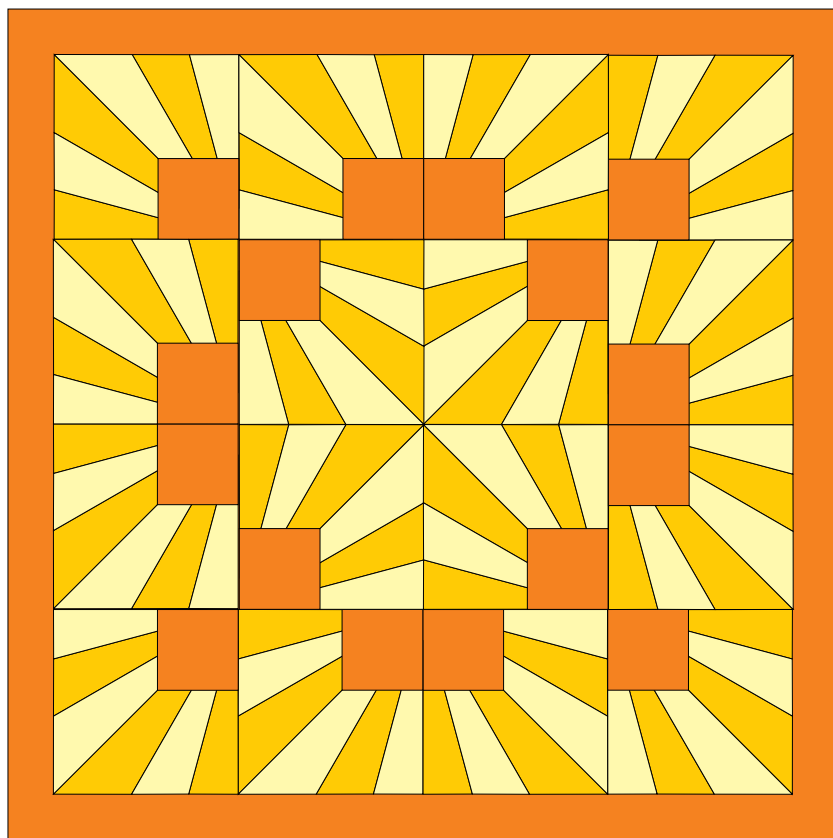

Finishing

- Assemble the Squedge blocks as shown.
- Add border pieces.
- Layer
- Quilt
- Bind

Enjoy!

Creative Options

We think using the Attic Window tool is a great way to cover the opening in the corner of every Squedge 15 block. You can also try this technique with the Squedge 22.5 and Squedge 11.25.

Try fussy cutting the Attic Window. Or adding embroidery to the Attic Window squares. It's a fun new way to play with both of your tools!!

Don't have an Attic Window tool? No problem. Just applique over the center opening or use the Squedge Corner Tool. Either way this is a great design using the Squedge 15!