

## March Blocks

March is the first month of our Striped Sampler Project. Stripes will work nicely for this project, but aren't an absolute necessity. For tips on working with stripes see our web site video page. (available March 15)

Here is the March block. If you also make the 3 design options, you could have 4 different blocks! Each month for the next few months, you'll get a new pattern. Make each one as a separate project, or make one per month for a sampler quilt by Christmas!

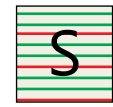
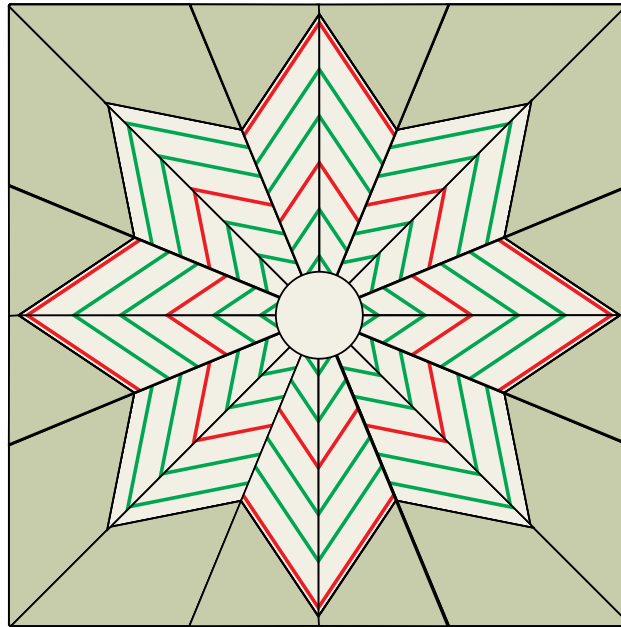

star

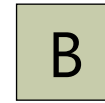

background

Finished block:  
16 1/2" square

Fabric	Exact Amount	Suggested Yardage <i>for a stripe running perpendicular to the selvage or an all over design</i>	Suggested Yardage <i>for a stripe running parallel to the selvage</i>
S	18"	5/8 yd*	1 1/4 yd
B	14 1/2"	1/2 yd	1 1/4 yd

\* May require more fabric depending on design repeats

Fabric	Number of Strips	Strip Width
S	four	4 1/2" x 44"
B	two	3 1/2" x 44"
	two	3 3/4" x 44"

To get exact matches with your striped points, be sure you cut identical strips from the striped fabric.

### Tool Preparation

- Apply adhesive non-slip rings to both the back and front side of the tool. You need to have these on both sides as you'll be cutting pieces with the tool flipped over.
- On the back side of the tool place a strip of pink glow tape on the 45 degree line as shown.
- Place a strip of yellow tape on the opposite 45 degree line.

*Using this tape has helped me keep the cuts straight. We'll continue to use these markings on the next few month's blocks. You can find the glow tape at many quilt shops and online stores, including mine.*

Notice the little slots in the tool? This is how you'll know where to cut the shorter Squedge pieces. Use a mechanical pencil to mark a line in each slot. Cut around the other sides of the tool, then remove the tool. Using a straight edge (or the outside oedge of this tool) connect the marked lines and cut across the bottom of the Squedge piece.

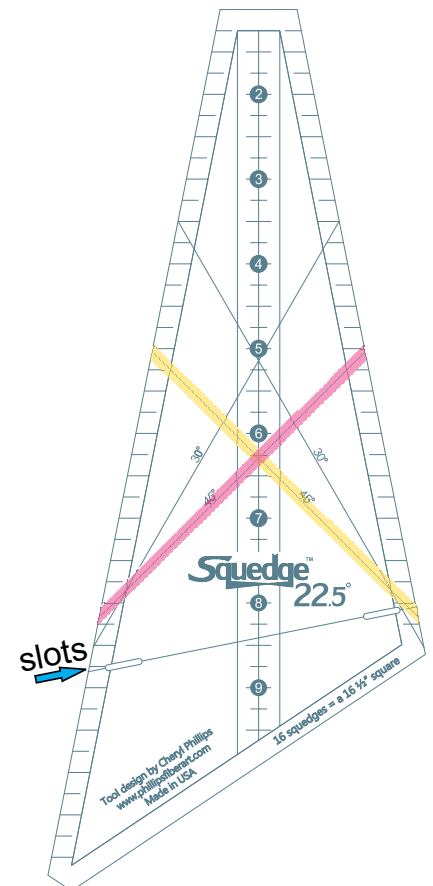

- Place the tool on the strip set so the **pink** 45 degree line is aligned with the seam.
- The words on the tool are **UP**.
- Cut the full tool shape.

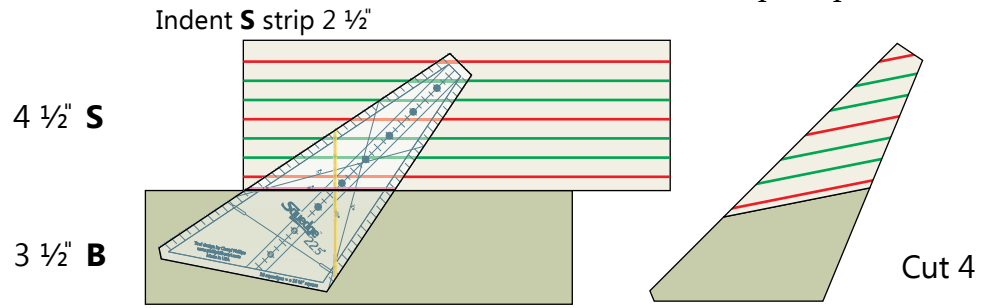

- Place the tool on the strip set so the **pink** 45 degree line is aligned with the seam.
- The words on the tool are **DOWN**.
- Cut the full tool shape.

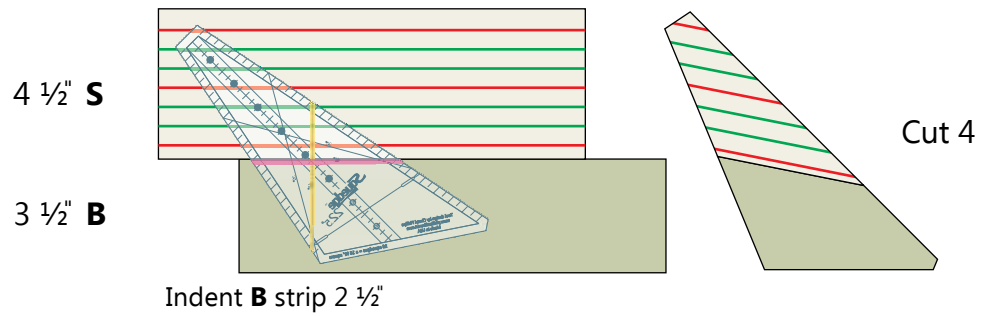

- Place the tool on the strip set so the **yellow** 45 degree line is aligned with the seam.
- The words on the tool are **UP**.
- Mark lines in the little slots.
- Cut a *partial* tool shape.

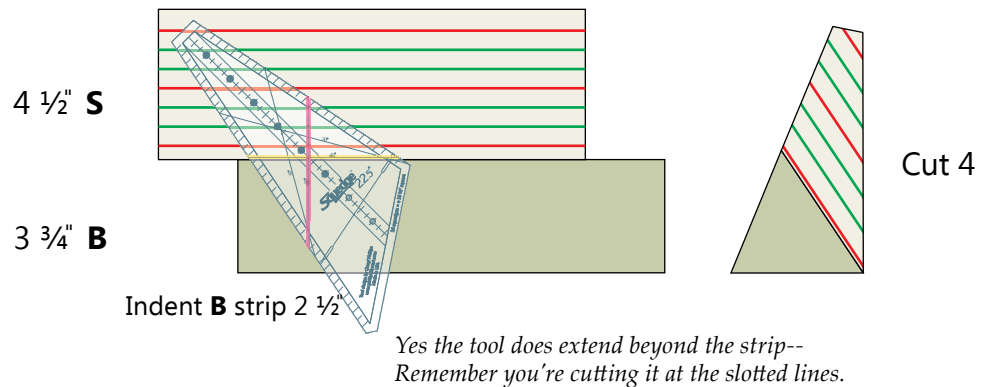

- Place the tool on the strip set so the **yellow** 45 degree line is aligned with the seam.
- The words on the tool are **DOWN**.
- Mark lines in the little slots.
- Cut a *partial* tool shape.

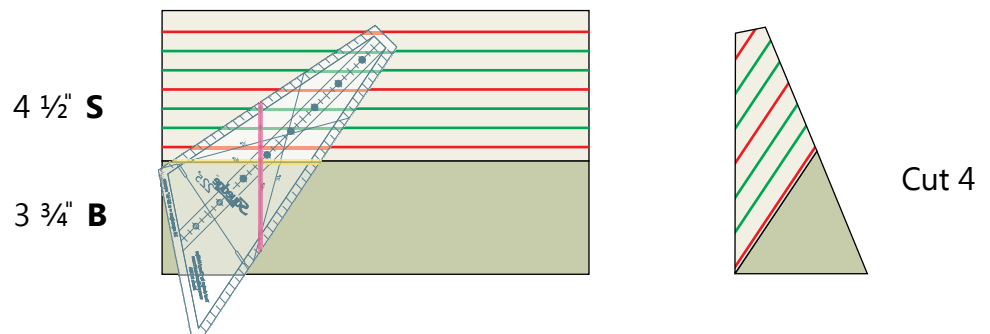

**Fabric Waste?**

You may notice you had quite a bit of strip set left after cutting the four pieces.

For these Sampler projects, you can

- Set these extra strip sets aside for next month's blocks
- Make more of the same blocks
- Try one of the block variations on page 4 or layouts on page 5

- Arrange the pieces as shown.
- Sew four together to make a quarter square.
- Sew the four quarter squares together to make the block.

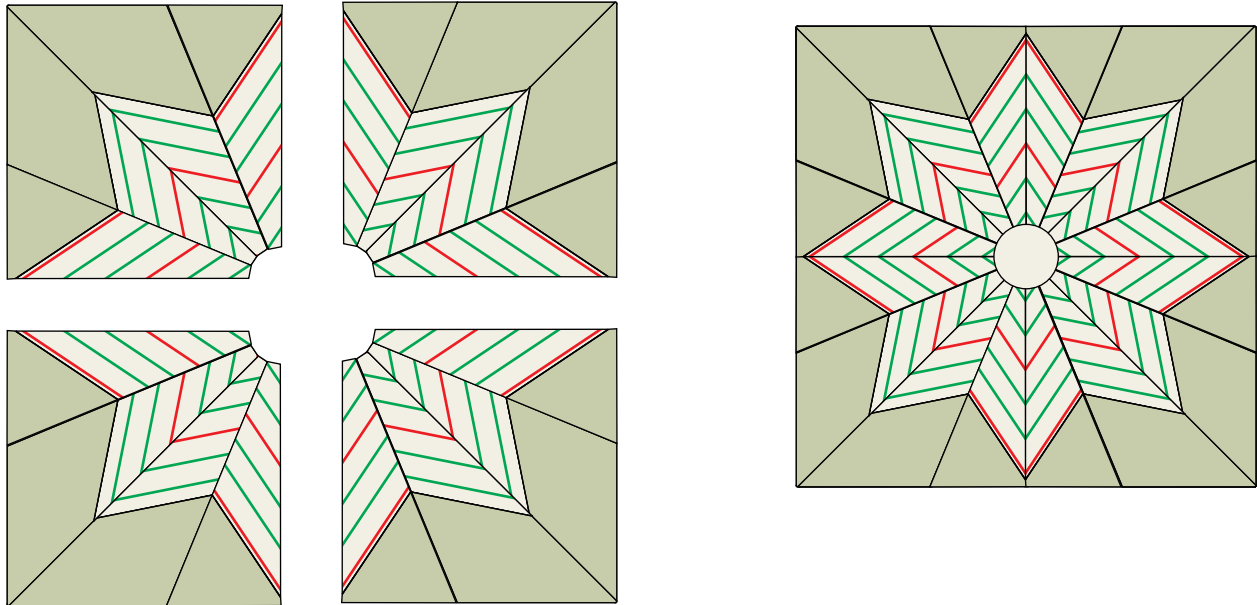
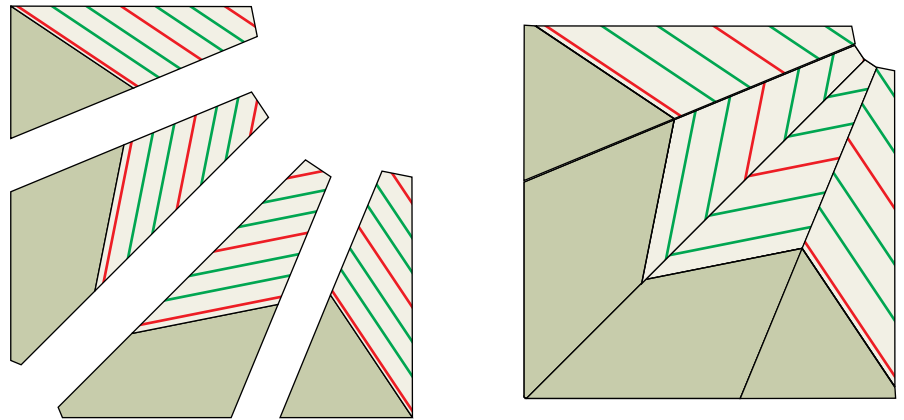

- Iron a square of freezer paper to the back of the project to stabilize the center opening.
- Trace a circle onto freezer paper.
- Iron the freezer paper onto a scrap of fabric you've chosen for your center applique.
- Cut the fabric, allowing ¼" for turning under.
- Applique the circle to the center opening.

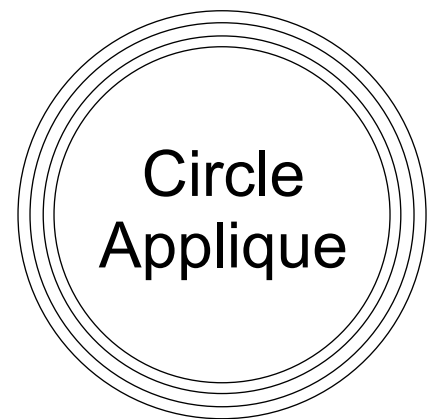

### Design Options

Simply rearranging the elements in this block can give you such different effects. It's really fun!

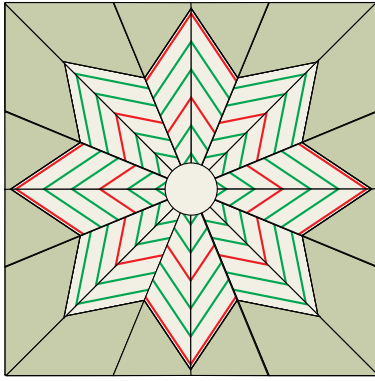

original block

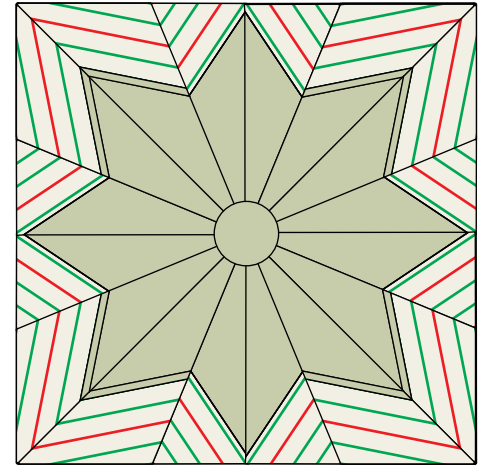
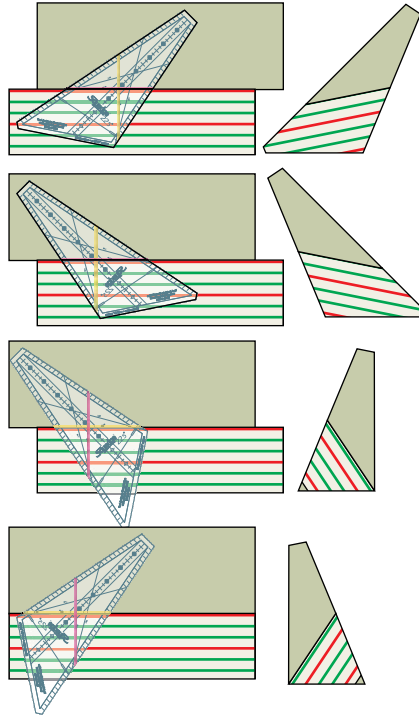

Option 1 block

#### Option 1 -- Changing places

- Use the stripe for the background and the background for the star.

Your strip sets will look like this:

#### Option 2 Rotating the Stripe

- Rotate the stripe so the lines are running vertical.

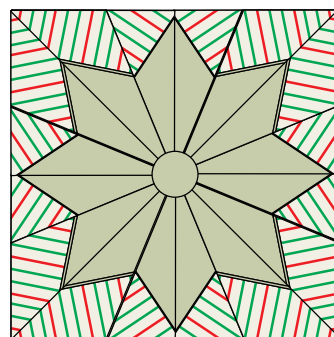
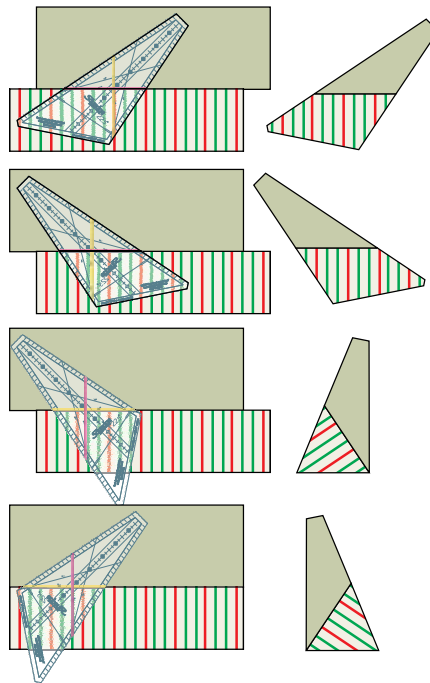

Option 2 block

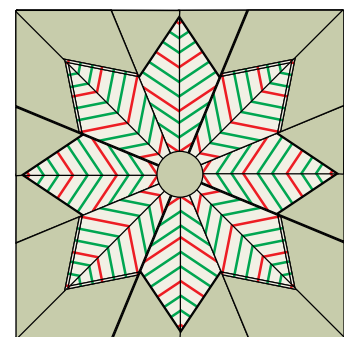
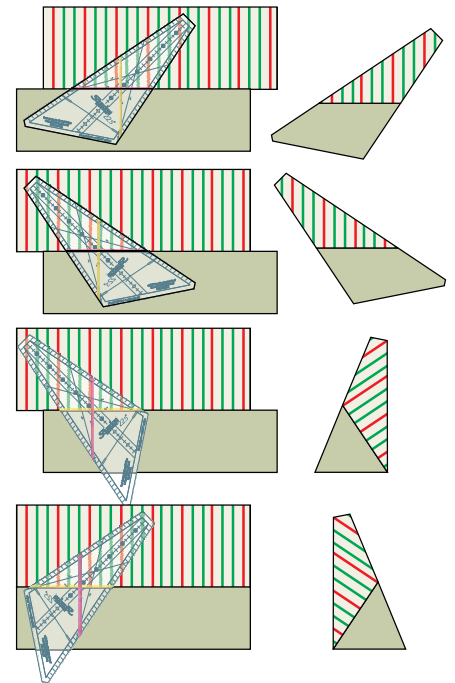

Option 3 block

#### Option 3 Rotating the Stripe and Changing Places

- Use the stripe for the background and the background for the star.
- Rotate the stripe so the lines are running vertical.

## Options For Finishing it Now

*Although the plan is to make a sampler, you can also use just this block for a great table runner or baby quilt. Simply make more blocks!*

